

UNINTERRUPTIBLE POWER SUPPLIES

UNINTERRUPTED Peace of Mind

9900C UPS
1050 kVA | 1000 kW

9900C UPS
1050 kVA | 1000 kW



 **MITSUBISHI
ELECTRIC**
UNINTERRUPTIBLE POWER SUPPLIES

MEGAWATT UPS

FOR HIGH DENSITY APPLICATIONS

The new 9900C is an exceptional addition to Mitsubishi's flagship 9900 series UPS family, providing over one megawatt of power in a single UPS. Delivering up to 97% efficiency, it is the first true on-line double conversion UPS at this power level to feature the highest efficiency at all load levels. In addition, it is smaller in size and lighter in weight than competing products. As one of the largest manufacturers of IGBT's in the world, Mitsubishi is able to achieve superior UPS performance and reliability through smarter control of the IGBTs. The 9900C incorporates Digital Signal Processor and Direct Digital Control to realize the full benefits of the latest generation of IGBTs, a reduced total cost of ownership, and improved PUE over conventional UPSs.

FEATURES & BENEFITS

- Up to 97% efficiency
- Can be paralleled with up to eight units for N+1 redundancy
- The small footprint delivers the highest power density per square foot in the industry
- The three-level conversion design enables an unprecedented 15 year lifetime on capacitors
- Smart phone and tablet compatible; wireless connection
- Three year warranty standard; five year warranty optional
- 3 x 350 kVA modules for capacity (redundant up to 700 kVA)
- LCD touch screen to show measurements, diagrams, text, history, and alarms

DRAWING

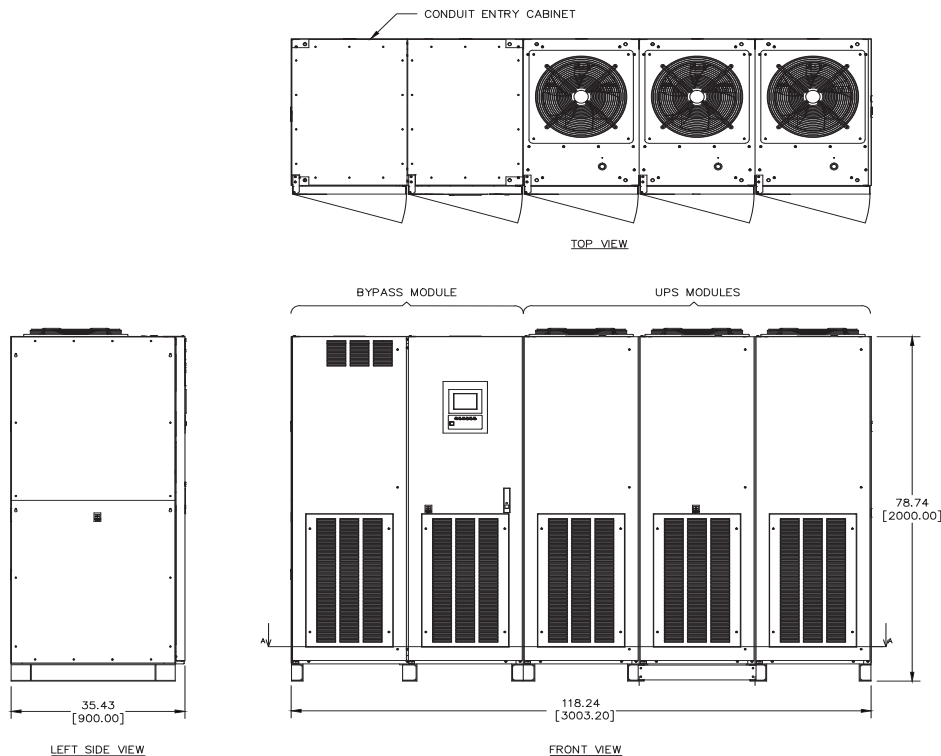

Reliable Backup Power

SPECIFICATIONS

AC INPUT	Configuration	3 phase, 3 wire
	Voltage	480 V
	Voltage Range	+15/-20%
	Frequency	60 Hz (±10%)
	Power Factor	>0.99 Lagging
	Input Current Distortion	< 3%
Reflected Current THDi	3% typ at 100% load	
	5% max at 50% load	
STATIC BYPASS INPUT	Configuration	3 phase, 3 wire
	Voltage	480 V
	Frequency	60 Hz ±5%
BATTERY	Nominal Voltage	480 V DC
	Minimum Voltage	400 V DC
	Float Voltage	Up to 600 V DC
	Max Charging Current	120 A

AC OUTPUT	Configuration	3 phase, 3 wire
	Voltage	480 V
	Frequency	60 Hz
	Voltage Adjustment	±3%
	Rated Load Power Factor	0.95
	Voltage Regulation	±1%
THD (VOUT)	2% max (linear load)	
	5% max (nonlinear load)	
Voltage Balance	1%	
Voltage Phase Displacement	±2° (100% balanced load) ±3° (100% unbalanced load)	
Step Load	±2% (< 20ms Recovery time)	
Overload Capacity	125% for 10 minutes; 150% for 60 seconds	
GENERAL	Operating Temperature	32° F to 104° F (0° C to 40° C)
	Relative Humidity	5% – 95% Non-Condensing
	Altitude	0 to 6500 feet (1980 m)
	Audible Noise	73 dB @ 1 m 60 Hz
	Efficiency (AC/AC)	Up to 97%
	Emergency Power Off	Included
	Parallel Capability	8 Units (MMS-kit option)
	Cable Entry	Top/Bottom
	Weight	6600 lb. (3000 kg)

SINGLE LINE DIAGRAM

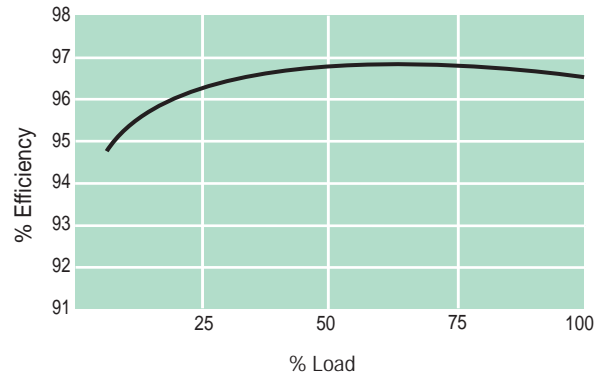
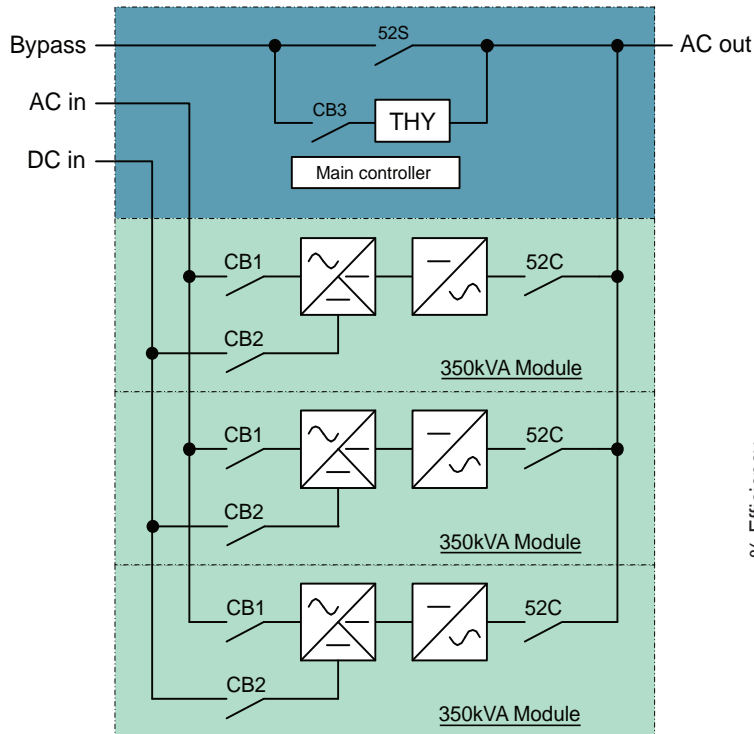

Typical Test Results

EFFICIENCY CURVE





Contact Information

Thorn Hill Industrial Park
547 Keystone Drive
Warrendale, PA 15086
phone: 724.772.2555
web: www.meppi.com



for a greener tomorrow

Like all other Mitsubishi UPS systems, the 9900C is an online double-conversion system and features Mitsubishi's world-renowned Insulated Gate Bipolar Transistor (IGBT) technology for enhanced UPS performance and reliability. Offering efficiencies up to 97%, the 1050kVA UPS supplies clean, continuous power to data centers and other mission critical equipment while reducing a facility's operating costs and carbon footprint.



Connect with us:



Since 1964, Mitsubishi Electric has manufactured precision-engineered high quality Uninterruptible Power Supplies (UPS) to protect mission critical equipment during times of power instability. Mitsubishi Electric Power Products' UPS systems are unsurpassed in reliability, quality and efficiency. We are dedicated to developing the best UPS systems on the market, and provide unrivaled service for the lifetime of your UPS.

The 9900C UPS is fully supported by Mitsubishi Electric Power Products' 24/7 factory service department, including customer training, application expertise and a three-year parts and labor warranty.

