

TOSHIBA

Leading Innovation >>>



One of the World's First to Feature Silicon Carbide (SiC) Technology

- Available in:
500 kVA/500 kW
750 kVA/750 kW
- Space-saving Compact Footprint
(500 kVA 59.1" x 33.5" x 80.6")
(750 kVA 84.7" x 33.5" x 80.6")
- True Online, Double-Conversion Technology
- Typical 98.2% AC-AC Efficiency
- Parallel Up to 8 Units
- Dual Input Design (Alternate Input for Bypass)
- All Digital Signal Processor Software
- Easily Accessible for Installation and Maintenance
- No Capacity Derating up to 40°C (104°F) and 1981 meters (6500 ft)
- RemotEye 4 Monitoring:
HTTP(S), SNMP, Modbus RTU & TCP, BACnet MSTP & IP

G2020 SERIES

UNINTERRUPTIBLE POWER SYSTEMS



▶▶▶ G2020 SERIES



MODEL	Model Number	T200H0500KWWW	T200H0750KWWW
	Capacity	500 kVA	750 kVA
AC INPUT	Configuration	3-Phase, 3-Wire	
	Voltage	480 V +15% to -20%	
	Frequency	60 Hz ±10%	
	Reflected Current THDi	3% Typical at 100% Load (No Input Filter Required)	
STATIC BYPASS INPUT	Configuration	3-Phase, 3-Wire	
	Voltage	480 V ±10%	
	Frequency	60 Hz ±5%	
BATTERY	Type	Lead Acid	
	Ride Through	Application Specific	
	Nominal Voltage	480 Vdc	
	Minimum Voltage	400 Vdc	
	Number of Cells	240	
	AC OUTPUT	Configuration	3-Phase, 3-Wire
Voltage		480 V	
Voltage Regulation		±1%	
Frequency		60 Hz	
Frequency Regulation		±0.01% in Free Running Mode	
Power Factor		Unity (Nominal)	
Power Factor Range		0.7 Lagging to 0.8 Leading (Within Output kW Rating)	
Voltage THD		2% Maximum THD at 100% linear load. 5% maximum THD at 100% non-linear load.	
Transient Response		±2% Maximum at 100% Load Step. ±1% Maximum at Loss/Return of AC Power ±5% Maximum at Load Transfer to/from Static Bypass	
Transient Recovery Time		Less than 20ms	
Voltage Unbalance		1% Maximum at 100% Unbalanced Load	
Phase Displacement		1° Maximum at 100% Load	
Inverter Overload		125% for 1 Minute; 150% for 10 Seconds	
Bypass Overload		500% for 1 Cycle (with Bypass Available)	
ENVIRONMENT		Cooling	Forced Air
	Operating Temperature	32°F to 104°F (0°C to 40°C). Recommended: 68°F to 86°F (20°C to 30°C)	
	Non-operating & Storage Ambient	-40°F to 158°F (-20°C to 70°C)	
	Relative Humidity	5% – 95% Non-Condensing	
	Altitude	0 to 6500 ft. (1981 m) No Derating at 104°F (40°C)	
	Location	Indoor (Free From Corrosive Gases and Dust)	
	Paint Color	Munsell N1.5 (Black)	
	Clearance Required	Top: 24 in. (610 mm); Front: 40 in. (1016 mm); Rear: 0 in. (0 mm); Sides: 0 in. (0 mm) if Sidecars Used, 1 in. (25 mm) if No Sidecars Used.	

G2020 Series UPS

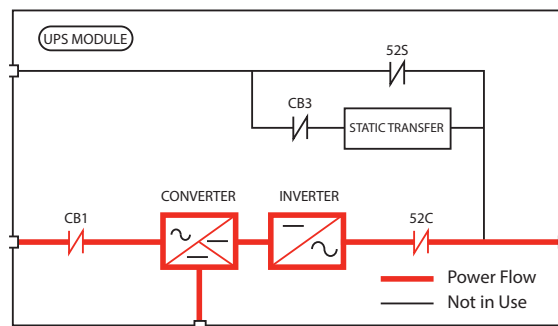

Efficiency Curve - Toshiba G2020 Series Double-Conversion UPS

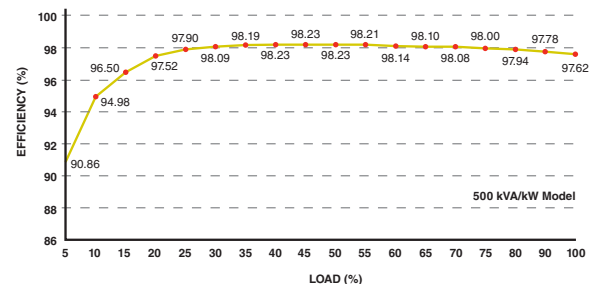

TOSHIBA POWER ELECTRONICS:

- Uninterruptible Power Systems
- Power Conditioners
- SCiB Rechargeable Battery

TOSHIBA
Leading Innovation ▶▶▶

www.toshibaups.com