

ASM

innovations in access flooring

Data Center Catalog

Flexibility, Strength, and Energy Savings

Raise your level of business with our patented, award winning, and industry leading raised access flooring systems.



Helping you become
LEED Certified



USA Design & Engineering + USA Quality & Testing
GLOBAL VISION



AirFlow

Perforated Panels,
Standard and Directional Grates

A complete array of cooling solutions for all applications and loading requirements.

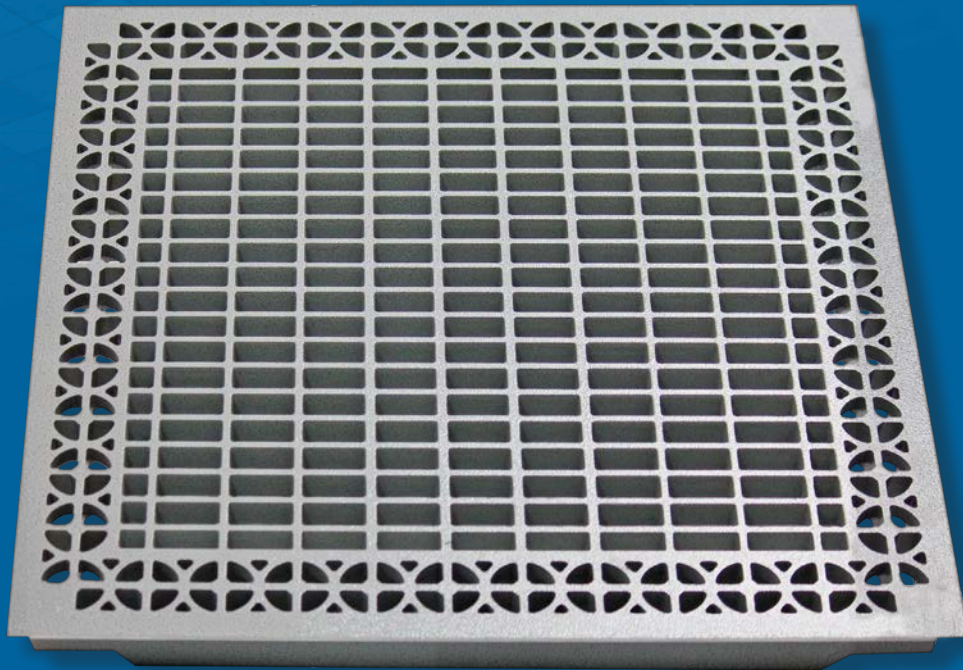

Data Center



Equipment Room



Technical Spaces

Keeping your servers cool

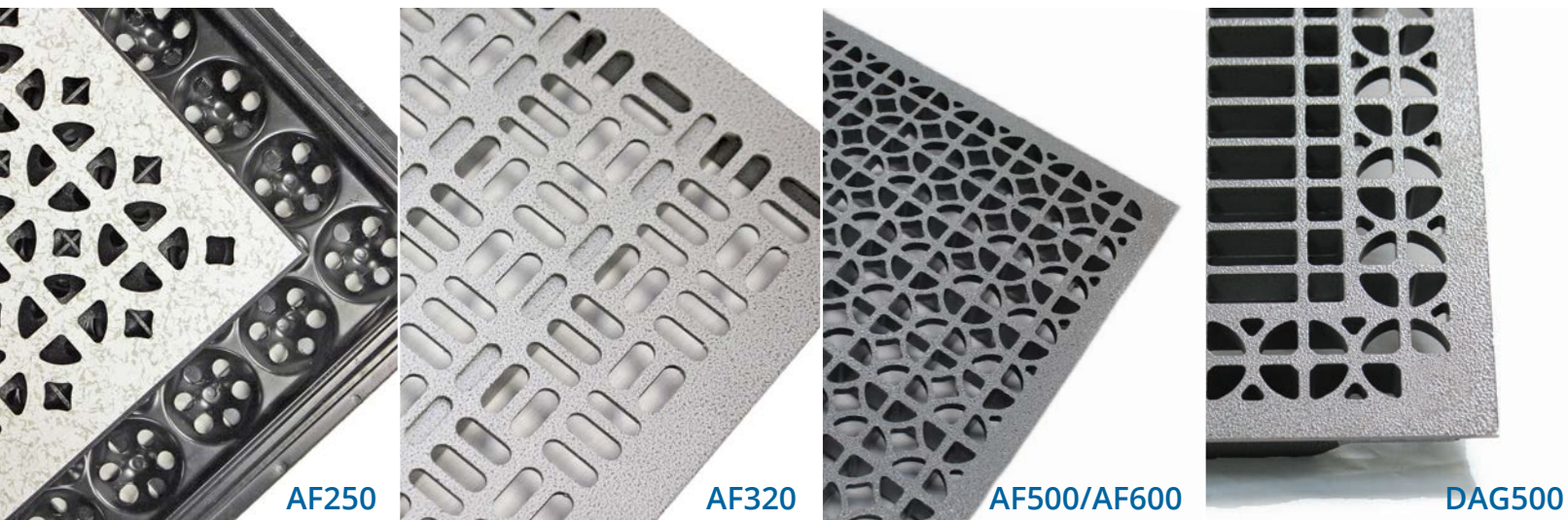

AF-Series Performance Guide

	AF250	AF320	AF500	AF600	DAG500 (Directional)
Concentrated Load Rating	1,000 lbf (4.45 kN)	1,500 lbf (6.67 kN)	1,750 lbf (7.79 kN)	2,500 lbf (11.12 kN)	2,000 lbf (8.90 kN)
Uniform Load Rating	400 psf (1,952 kg/m ²)	800 psf (3,904 kg/m ²)	500 psf (2,440 kg/m ²)	700 psf (3,416 kg/m ²)	500 psf (2,440 kg/m ²)
Ultimate Load Rating	3,200 lbf (14.23 kN)	4,500 lbf (20.00 kN)	3,500 lbf (15.57 kN)	5,000 lbf (22.24kN)	4,200 lbf (18.68 kN)
Impact Load Rating	175 lb (79 kg)	300 lb (136 kg)	175 lb (79 kg)	200 lb (91 kg)	175 lb (79 kg)
ROLLING LOAD RATING:					
10-Pass Test	400 lbf (1.78 kN)	1,500 lbf (6.67 kN)	2,000 lbf (8.90 kN)	2,500 lbf (11.12 kN)	1,500 lbf (6.67 kN)
10K-Pass Test	400 lbf (1.78 kN)	1,250 lbf (5.56kN)	2,000 lbf (8.90 kN)	2,500 lbf (11.12 kN)	1,250 lbf (5.56 kN)
At 0.10 Static Pressure without Damper	610 CFM	2060 CFM	3060 CFM	3060 CFM	3220 CFM
Open Area	25%	32%	56%	56%	62%

Panels are tested per Cisca Recommended Test Procedures for Access Floors on actual support understructure.

A minimum safety factor of 2 is recommended by international standards and building codes.

Product List



AF250 Steel Air Flow Perforated Panel

ASM's AF250 perforated panel has a free open area of 25% and is available with optional mechanical damper.

- 25% Open area for high volume air flow
- 24" or 600 mm size
- Available with top-adjusting slide dampers
- Completely interchangeable with FS-Series and S-Series panel systems
- High pressure laminate finish

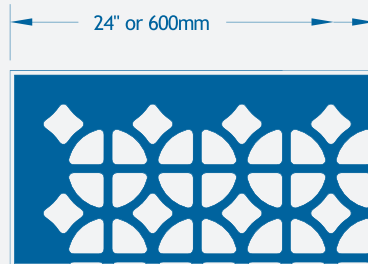

PARTIAL TOP VIEW

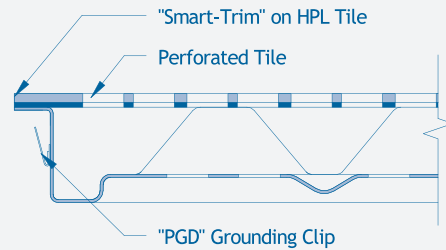

PARTIAL SIDE VIEW

AF500 and AF600 Aluminum Air Grate

For cold aisles, the Accel-Air is a strong and durable panel with a free open area of 56% for those applications requiring the highest cooling conditions. Accel-Air panels come standard with powder coat ESD epoxy finish.

- 56% Open area for high volume air flow
- 24" or 600 mm size
- Available with top-adjusting slide dampers or opposed blade dampers
- Completely interchangeable with FS-Series and S-Series panel systems
- Die cast aluminum construction
- Suitable for clean room applications
- Made of 100% recycled material
- ESD Conductive epoxy paint finish

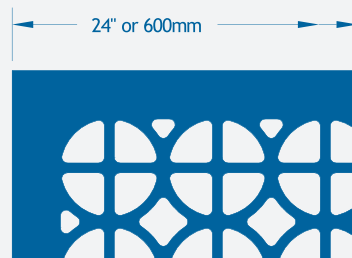

PARTIAL TOP VIEW

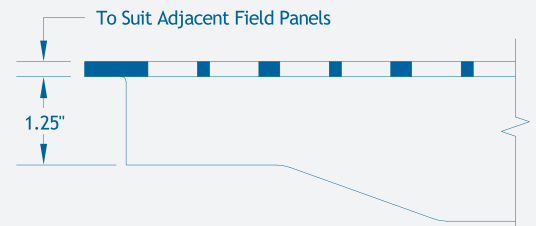

PARTIAL SIDE VIEW



AF320 Steel Air Flow Perforated Panel

With 32% open area, the AF320 offers an intermediate amount of air delivery, while maintaining high strength. The AF320 offers additional flexibility when balancing and cooling in the data center.

- 32% Open area for high volume air flow
- Completely interchangeable with FS-Series and S-Series panel systems
- Green rated, uses 82% recycled material
- Rated at 1,500 lb concentrated load and 4,500 lb ultimate load
- Welded steel assembly with standard ESD powder coated finish

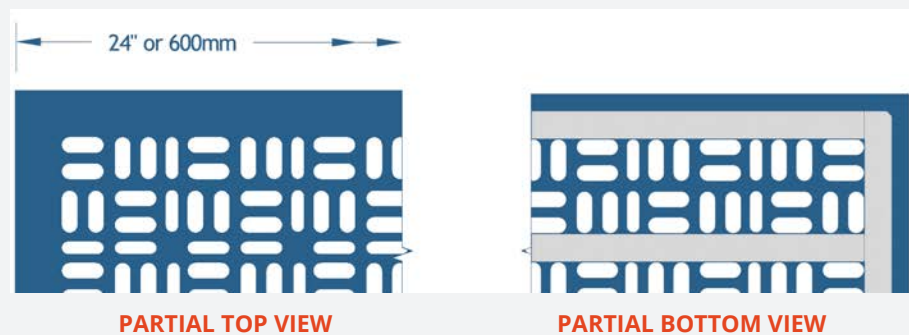

DAG500 Directional Aluminum Air Grate

The high strength directional air grate has a load rating of 2,000 lbf to ensure top performance in the ever increasing loads of today's data center. The angled rib design directs air flow towards the front of the equipment allowing for more efficient air delivery and cooling.

- 61.3% Open area
- Available in 24" size
- ESD finish powder coat epoxy paint
- Corner-Lock feature available
- 100% Variable damper setting
- Adjustable from top of panel
- Die cast aluminum construction
- Available with adjustable dampers

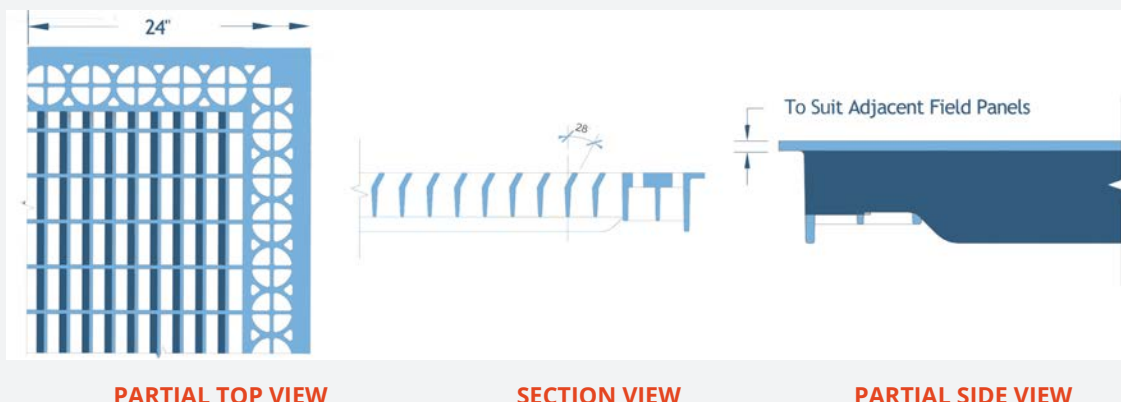
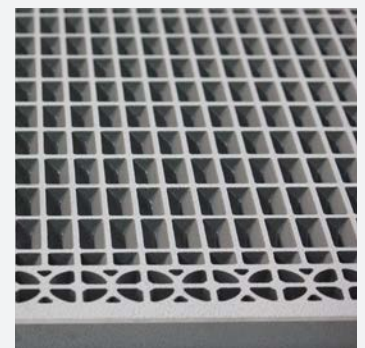

FS-Series

Filled Steel Panels

The most specified product for data center applications, with 6 different load ratings.

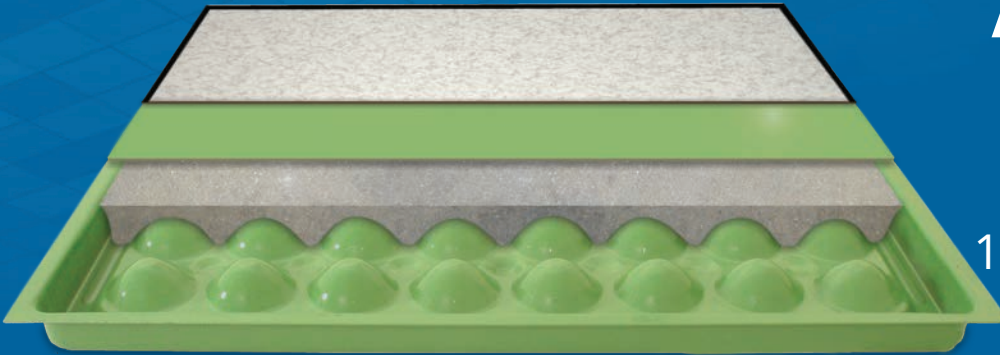

ASM's Enviro Panel:
Up to 3,000 lbf design load /
10,000 lbf Ultimate load

FS-Series Performance Guide

PANEL	CONCENTRATED DESIGN LOADS		SAFETY FACTOR MIN.2x	ULTIMATE LOADS		UNIFORM LOADS		IMPACT LOADS		ROLLING LOADS			
	(lbf)	(kN)		(lbf)	(kN)	(psf)	kg/m ²	(lb)	(kg)	10 PASS		10K PASS	
										(lb)	(kg)	(lb)	(kg)
FS100	1000	4.45	PASS	3300	14.68	500	2240	175	79	900	408	700	310
FS200	1250	5.56	PASS	3900	17.35	600	2928	175	79	1150	522	900	408
FS300	1500	6.67	PASS	5400	24.02	700	3416	175	79	1300	590	1100	499
FS400	2000	8.90	PASS	6300	28.02	800	3904	200	91	1600	726	1300	590
FS500	2500	11.12	PASS	7000	31.14	900	4393	200	91	2200	998	2000	907
FS600	3000	13.34	PASS	10000	44.48	1000	4881	400	181	3000	1361	3000	1361

ASM is proud to lead the industry with our steel panel design, by developing the first 3,000 lbf. rated cementitious filled welded steel panel. We have engineered the FS600 to support a 3,000 lbf. design load with rolling loads in excess of 3,000 lbf. when tested per CISCA.

FS-Series Technical Information

Physical Data

- Fire Rating of Bare Panel:
 - Class A Flame Spread (Per ASTM E84)
 - Non-Combustible Materials (Per ASTM E136)
- Electrical Resistance
 - ASTM/NFPA 99A

Finish Options

- HPL Tile (1/16" or 1/8")
 - ASM "Smart-Trim", "Dura-Trim" or "monolithic"
 - HPL Corner-Lock
- Vinyl Tile:
 - VPT "Con-Tile" (static conductive)
 - VPT "Stat-Tile" (static dissipative)
- Rubber Tile:
 - Antistatic
 - Standard
- Custom finishes

Contact ASM for tile color options

Understructure Options

- Rigid Grid Bolted Stringers:
 - 2' x 2' System
 - 2' x 4' System
 - 4' x 4' Basketweave system
- Corner-Lock
- Hot dip galvanized and nickel chrome
- Seismic pedestals and bracing

Features

- Available in 24" or 600 mm size
- Powder coat epoxy paint finish
- Welded steel construction
- Full-Strength deep drawn corners
- Light weight cementitious fill
- Recycled materials

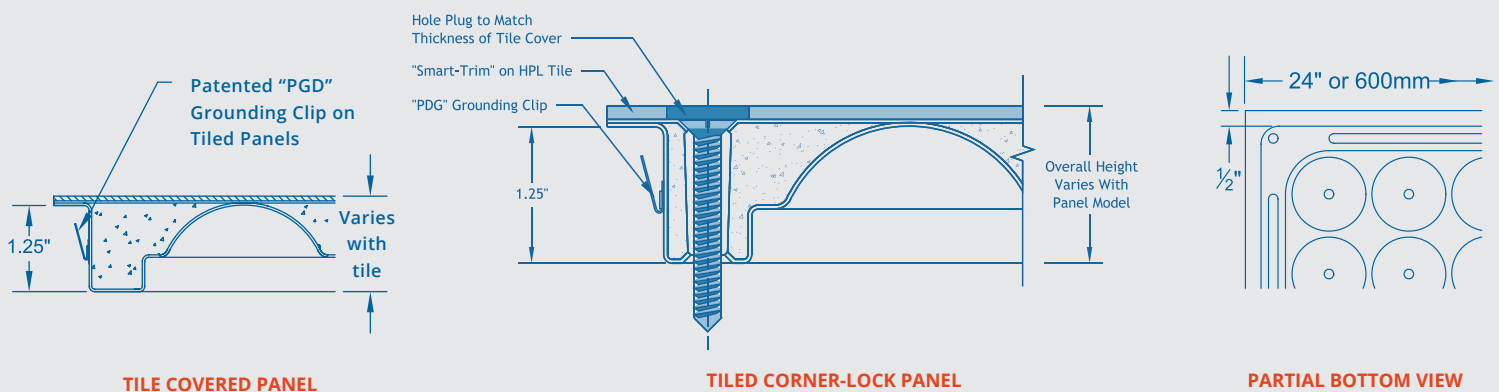

EQUIPSECURE

Seismic Systems

Don't Waste Your Time & Money
on Complicated Bracing Schemes

3 Easy Steps

1. Determine seismic pedestal system to install under equipment
2. Install ASM EQUIPsecure system under equipment
3. Bolt equipment to access floor panels

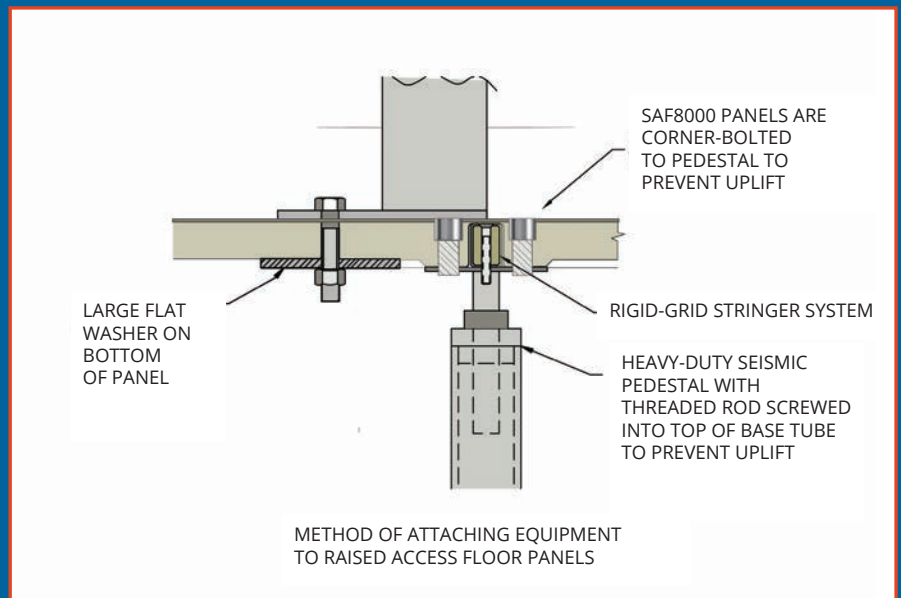
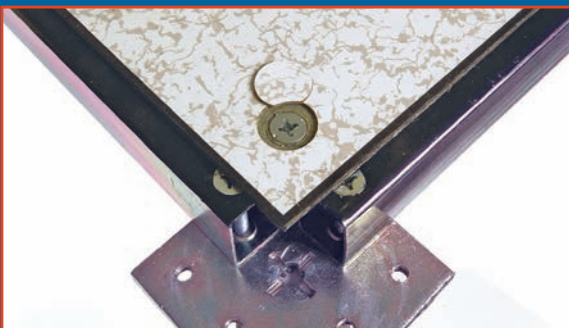

SAF8000 Equipment Mounting Panel

PHYSICAL DATA

- 24" or 600 mm size
- Weight of bare panel: 72 lb.
- Fire rating of bare panel:
 - Class A flame spread
 - Non-Combustible materials



PERFORMANCE DATA

- Concentrated load rating: 8,500 lbf (37.8 kN)
- Uniform load rating: 2,500 psf (12,201 kg/m²)
- Ultimate load rating: 20,000 lbf (89 kN)
- Safety factor: 2.5
- Impact load rating: 1,000 lb. (454 kg)
- Rolling load rating:
 - CISC Wheel C (10 Pass): 8,000 lbf (35.7 kN)

FINISH OPTIONS

- HPL tile (1/16" or 1/8"):
 - ASM "Smart-Trim", "Dura-Trim", or "Mono"
- Vinyl tile:
 - VPT "Con-Tile" (Static Conductive)
 - VPT "Stat-Tile" (Static Dissipative)
- Rubber tile:
 - Antistatic
 - Standard
- Epoxy paint or mill finish

UNDERSTRUCTURE OPTIONS

- Corner-Bolted
- Rigid grid bolted stringers
 - 2' x 2' System
 - 2' x 4' System
 - 4' x 4' Basketweave system
- Pedestals are sized to suit application

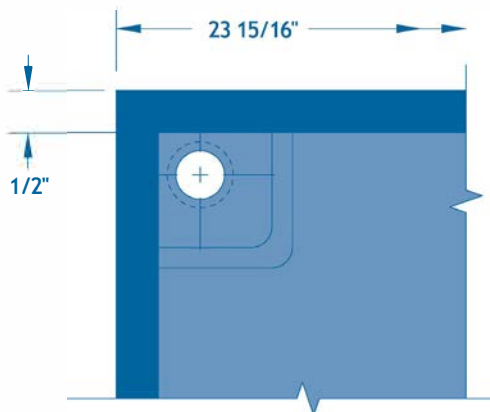

SAF8000 BOTTOM VIEW

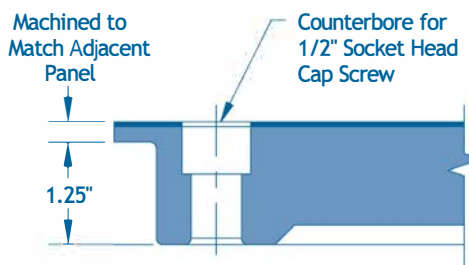

SAF8000 BARE CORNER-LOCK PANEL WITH SOCKET HEAD CAP SCREW

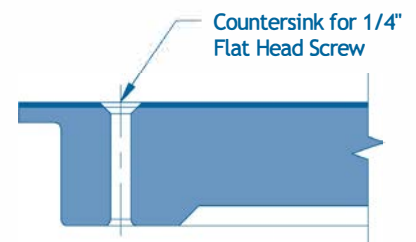

AL8000 BARE CORNER-LOCK PANEL WITH STANDARD 1/4-20 FASTENER

Understructure

ASM offers the most comprehensive variety of support types, providing economical solutions for non-seismic to high risk seismic regions. This full line of pedestals can further be strengthened by bolting them to the concrete slab or in combination with ASM's seismic bracing for the most solid and seismic resisting access flooring systems available.



Typical Understructure Configuration

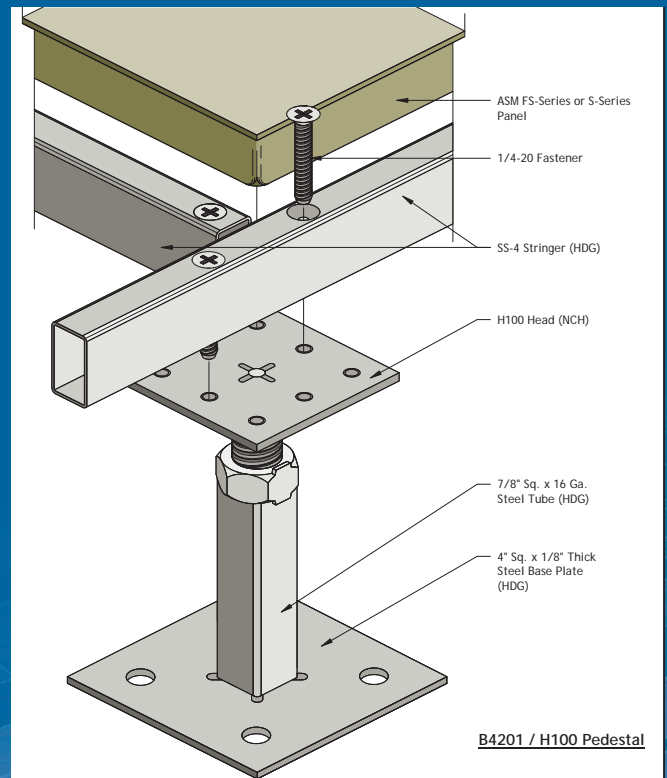

Every ASM stringer boasts solid tube construction to resist bowing and spreading during heavy loads. A factory applied solid vinyl gasket creates a quiet fit between the stringer and panel.

Product List

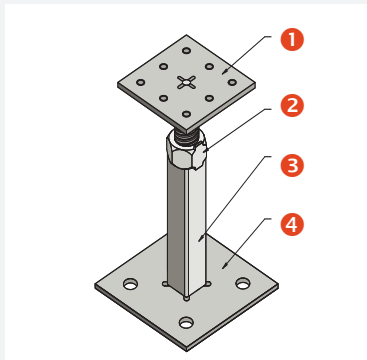

B4201/H100

1 H100 Head (NCH) 2 Adjusting Nut
3 7/8" Sq. x 16 Ga. Steel Tube (HDG)
4 4" Sq. x 1/8" Thick Steel Base Plate (HDG)

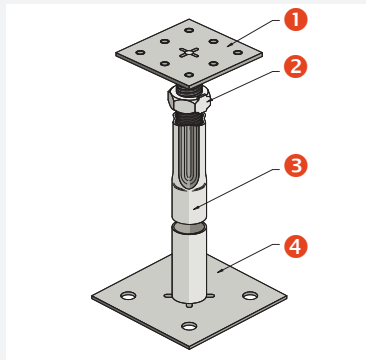

B42M10/H100

1 H100 Head (NCH) 2 Adjusting Nut
3 B42m10 Base Assembly 1" Dia. x 16 ga. Wall Structural Steel Tube Swaged for 3" Length to Accept a 3/4" Dia. Rod and Welded to Base Plate (HDG) 4 4" Sq. x 2.0 mm Thick Steel Base Plate (HDG)

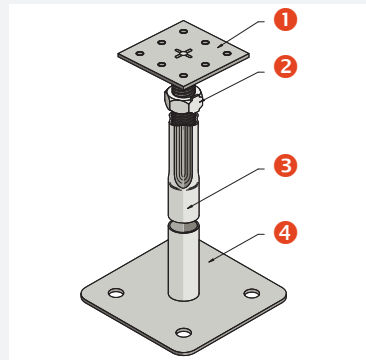

B5210/H100

1 H100 Head (NCH) 2 Adjusting Nut
3 B5210 Base Assembly 1" Dia. x 16 ga. Wall Structural Steel Tube Swaged for 3" Length to Accept a 3/4" Dia. Rod and Fillet Welded to Base Plate (HDG) 4 5" Sq. x 1/8" Thick Steel Base Plate with (4) 7/16" Dia. Anchor Holes @ 3-5/8" C-to-C Distance (HDG)

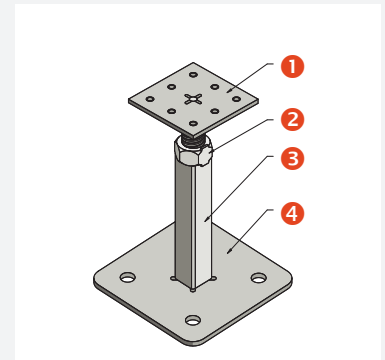

B54M01/H100

1 H100 Head (NCH) 2 Adjusting Nut
3 7/8" Sq. x 16 Ga. Steel Tube (HDG)
4 5" Sq. x 4.0mm Thick Steel Base Plate (HDG)

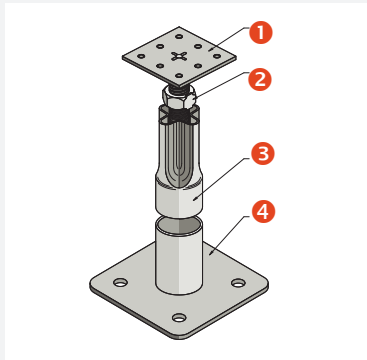

B5318A/H100

1 H100 Head (NCH) 2 Adjusting Nut
3 B5318 Base Assembly 1-3/4" Dia. x 16 ga. Wall Structural Steel Tube Swaged for 4" Length to Accept a 3/4" Dia. Rod and Fillet Welded to Base Plate (HDG) 4 5" Sq. x 5mm Thick Steel Base Plate with (4) 7/16" Dia. Holes @ 3-5/8" C-to-C Distance (HDG)

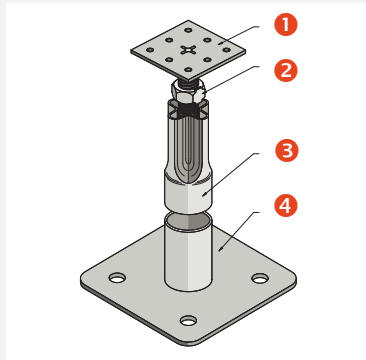

B6318A/H100

1 H100 Head (NCH) 2 Adjusting Nut
3 B6318A Base Assembly 1-3/4" Dia. x 16 ga. Wall Structural Steel Tube Swaged for 4" Length to Accept a 3/4" Dia. Rod and Fillet Welded to Base Plate (HDG) 4 6" Sq. x 5mm Thick Steel Base Plate with (4) 9/16" Dia. Holes @ 4-1/4" C-to-C Distance (HDG)

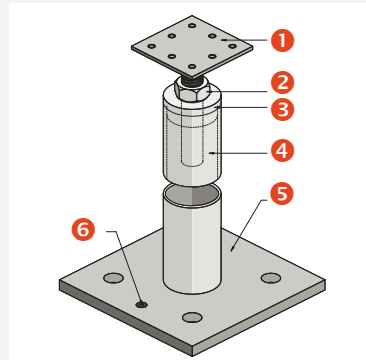

B6613A/H100

1 H100 Head Assembly 3-1/4" Sq. x 4mm Thick Head Plate with (8) 1/4-20 Tapped Holes Fillet Welded to 3/4" Dia. x 4" Long Solid Steel Threaded Rod (NCH) 2 3/4-10 Jam Nut 3 1" Thick Solid Steel Insert With 3/4-10 Threaded Hole Welded to Base Tube (HDG) 4 1.660 O.D. x 1.380 I.D. Structural Steel Pipe Fillet Welded To Base Plate (HDG) 5 6" Sq. x 3/8" Thick Steel Base Plate with (4) 9/16" Dia. Holes @ 4-1/4" C-to-C Distance (HDG) 6 1/4-20 Tapped Hole For Ground Connection

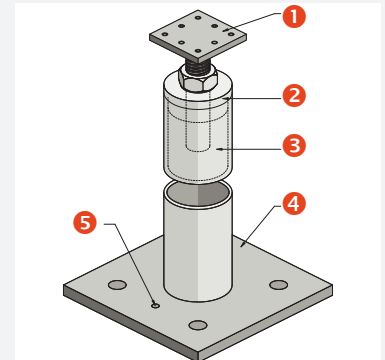

B8825C/H225

1 H225 Head Assembly 3" Sq. x 1/4" Thick Head Plate with (8) 1/4-20 Tapped Holes Fillet Welded to 1"-8 x 4" Long Solid Steel Threaded Rod (NCH) 2 1" Thick Solid Steel Insert With 1"-8 Threaded Hole Welded to Base Tube (HDG) 3 2.875 O.D. x 2.323 I.D. (2-1/2" Sched. 80 Pipe Size) Structural Steel Tube Fillet Welded To Base Plate (HDG) 4 B8825C Base Assembly 8" Sq. x 1/2" Thick Steel Base Plate with (4) 3/4" Dia. Holes @ 5" C-to-C Distance (HDG) 5 1/4-20 Tapped Hole For Ground Connection

* NCH - Nickel Chrome

* HDG - Hot Dipped Galvanized



Helping you become
LEED Certified



USA Design & Engineering + USA Quality & Testing
GLOBAL VISION

Product List

Stringers

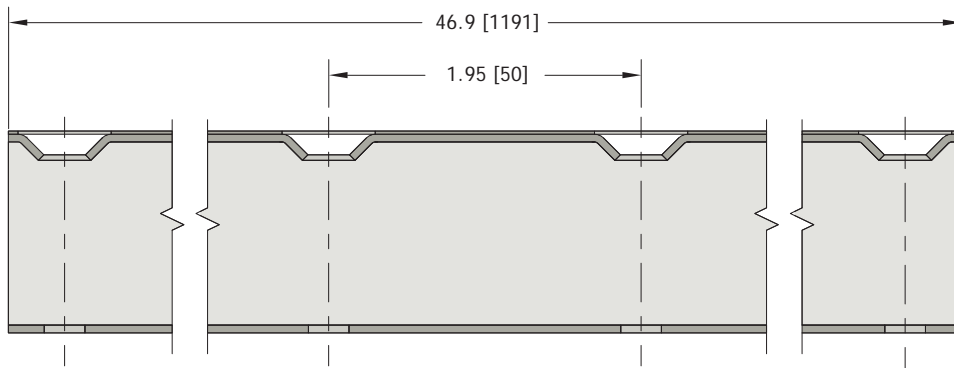

SIDE SECTION VIEW

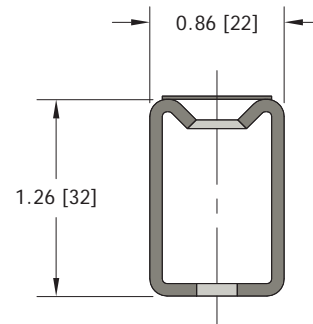
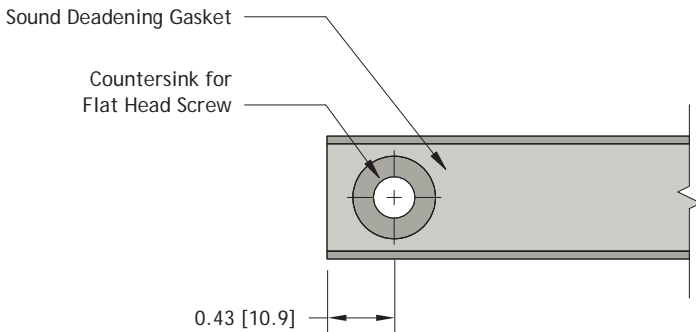

TOP END VIEW

END SECTION VIEW

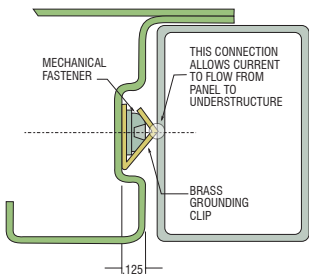

Patented PGD Electrical Grounding Clips

Is your floor grounded? If there is electrical build-up or a grounding problem on top of the floor, it can cause major problems and shut down your system.

ASM is the only manufacturer to comprehensively address grounding problems by incorporating a solid brass patented Positive Grounding Device (PGD) on every tile covered panel in a rigid grid system as standard equipment. A small detail solves a critical problem. The PGD is not required for the Corner-Lock system as it has a 1/4-20 Fastener with paint cutting teeth for Positive Electrical Contact between panel and pedestal.

Understructure Seismic Bracing

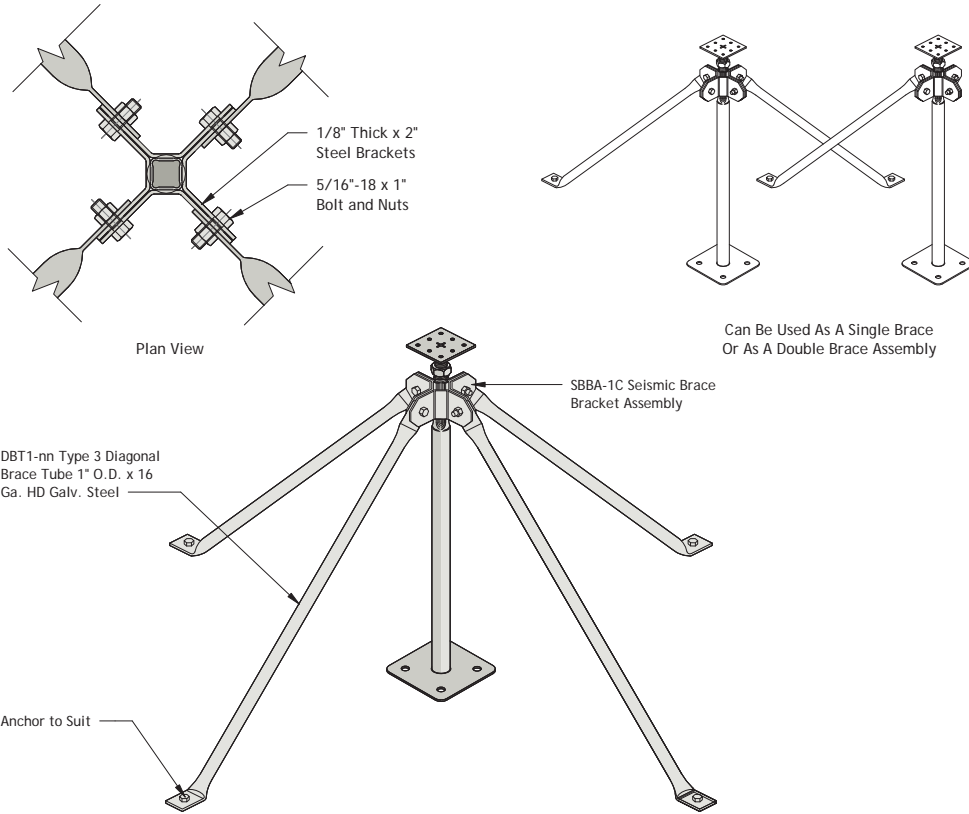

Understructure Bridging

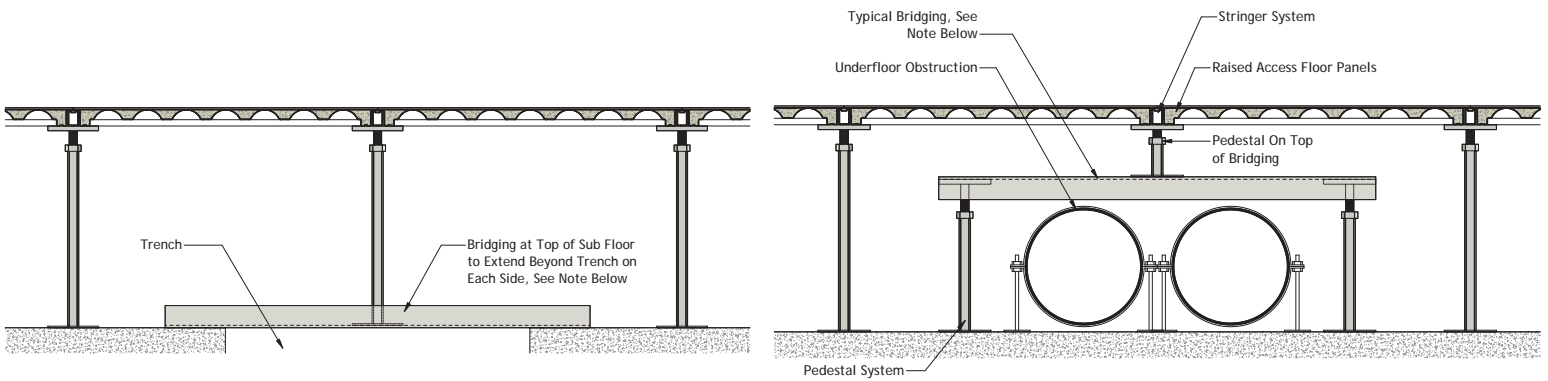

Bridging Note: C-Channel or I-Beam Structural Steel, Size and Spacing to be Engineered for Required Floor Loads

Flooring Finishes

High Pressure Laminate (HPL)

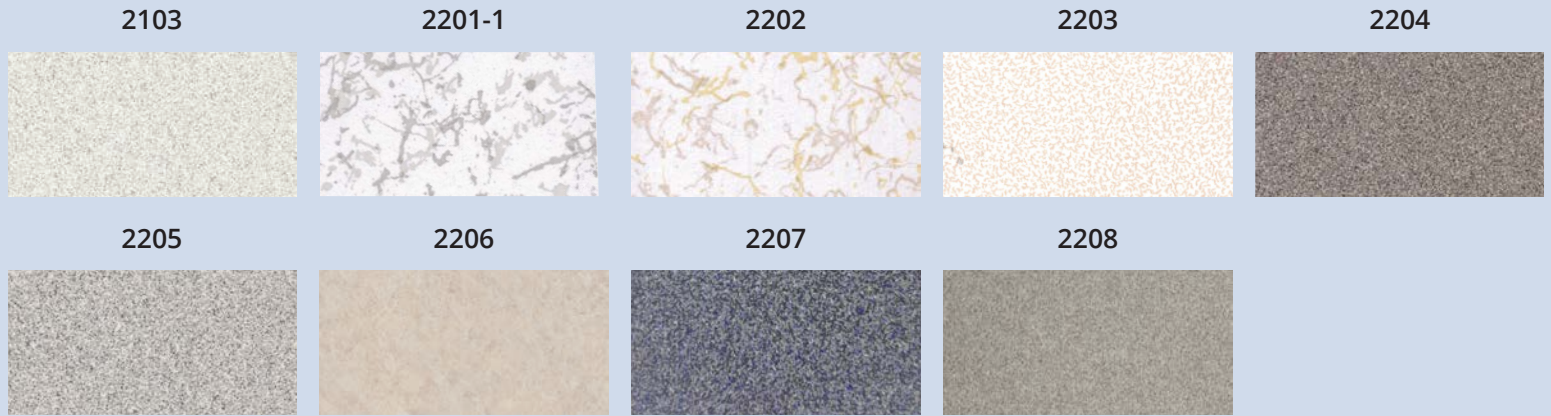

Properties	NEMA Test Method	NEMA Standard	ASM Laminate Results
Electrical Resistance	NFPA 99	-	$1.0 \times 10^6 - 2.0 \times 10^{10}$
Stain Resistance	3.4	No effect	No effect
Boiling Water Resistance	3.5	No effect	No effect
High Temp. Resistance	3.6	Slight effect	No effect
Wear Resistance	3.13	3000 cycles/min.	3000 +
Scuff Resistance	3.16	No effect	No effect

Vinyl Plastic Technologies (VPT)



Performance	Conductive	Static Dissipative
Resistance: point to ground	2.5×10^4 to $10^6 \Omega$	$10^6 \Omega$ to $10^8 \Omega$
Resistance: point to point	2.5×10^4 to $10^6 \Omega$	
Static Decay	5000 to 0 volts in < 0.01 sec	5000 to 0 volts in < 0.2 sec
VPT Sizes: 24 inch x 24 inch, 12 inch x 12 inch, 60 cm x 60 cm, 30 cm x 30 cm, Custom size if requested		

Accessories



Solid and Airflow Lifter Kit

Designed to make installations and alterations simple. They can be easily stored on Lifter Wall Mount Brackets.



Rails

The ASM Handrail System is a modular clear anodized extruded aluminum railing.



Ramp & Steps

Modular components for any size or application.



Logo Panels

Custom designs and logos incorporated into laminate finish.



Grommets

Round, square, and brush type in a multitude of sizes.



Seismic Braces

For high risk seismic projects, ASM offers seismic braces that can easily be attached to any ASM raised floor pedestal for ultimate lateral support.

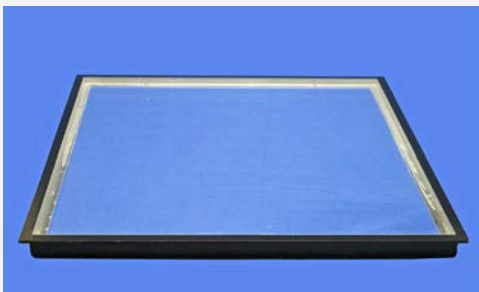

Clear View Panel

High strength acrylic allows you to monitor underfloor area without removing panels.



Electrical Box

Multiple floor box options integrated into panel system.



Frost-Byte

Booster unit for air grate where underfloor pressure is insufficient.



In addition to being the largest access flooring manufacturer in the world, the Kingspan group is a major manufacturer of an integrated range of products for the construction industry. The Group continues to innovate and improve on an existing product range, and have done so successfully for over 30 years. These innovations are clearly seen within Kingspan's emphasis on modern Methods of Construction and importance on increasingly sustainable buildings. The Group's companies have a presence around the world that is ever increasing.

For more information about Kingspan please visit us at www.kingspan.com.



Flexibility, **Strength**, and Energy Savings

(888) 279 - 9216 Toll Free | (843) 534 - 1110 Local | (843) 534 - 1111 Fax

9500 Industrial Center Drive | Ladson, South Carolina 29456 USA

www.asmproducts.com

Manufacturing | Sales | Distribution
WORLDWIDE